

MICHELONI PORTE

IN LEGNO MASSELLO

CATALOGO COLLEZIONI
PORTE INTERNE IN LEGNO MASSELLO

INDICE

LE CLASSICHE:

Classica.....pag. 8
Decori.....pag. 58

Classica Slide.....pag. 62

Millenium.....pag. 76

LE MODERNE:

Moderna.....pag. 88

New Line.....pag. 112

Cubica.....pag. 130

LE ESSENZIALI:

Style.....pag. 148

Linear/
Linear Buganata.....pag. 164

SOLUZIONI D'ARREDAMENTO:

Sensi di Apertura.....pag. 186

Cimase e Capitelli... pag. 200

Telai e Coprifili.....pag. 202

Essenze e Finiture... pag. 204

Vetri.....pag. 206



**100% MICHELONI
100% ARTIGIANALITÀ
100% MADE IN ITALY**

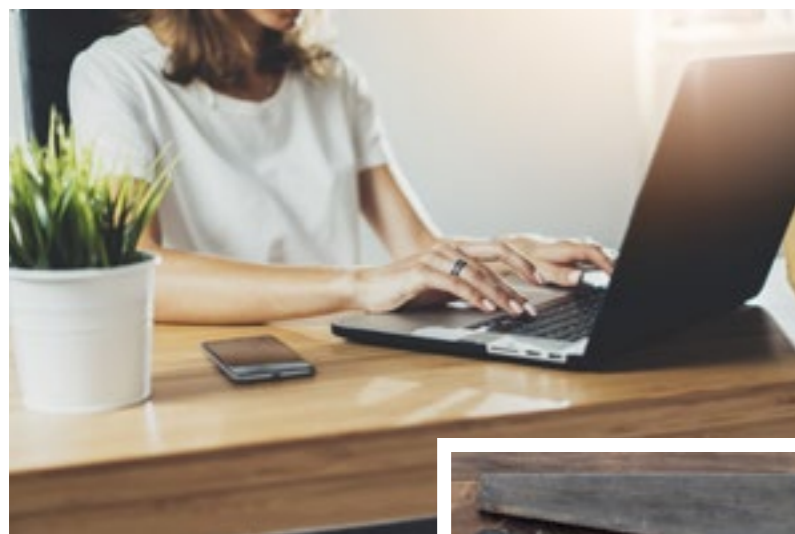

Michelsoni Porte, la fusione perfetta tra tradizione e innovazione.

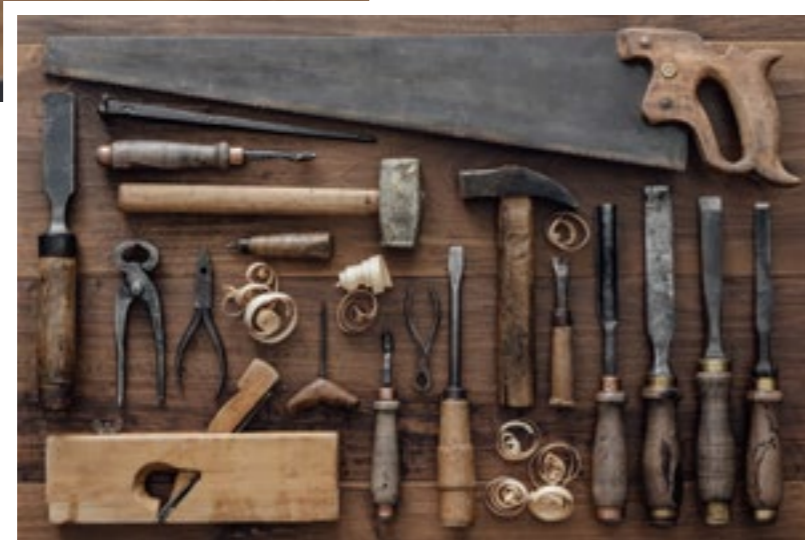

Ambiente e materia al primo posto.

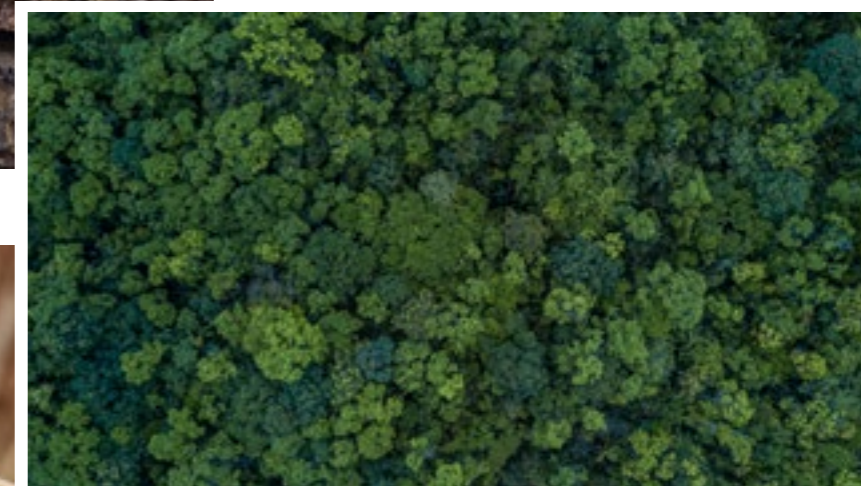

Michelsoni Porte è una moderna realtà produttiva tecnologicamente all'avanguardia nello studio e nella progettazione di porte da interno in legno massello.

Un'attenzione artigianale attraversa tutte le fasi della lavorazione delle porte Michelsoni; la scelta delle materie prime, la cura dei particolari, delle finiture, dei dettagli.

La continua ricerca e l'attenzione alle tendenze più aggiornate del design di interni, si traducono in un'ampia gamma di modelli di elevato valore qualitativo, progettati e realizzati pensando "l'oggetto porta" non come complemento ma come elemento di arredo.

La passione per il legno la ricerca costante di materie prime di assoluto livello qualitativo sono alla base della filosofia Michelsoni Porte. La nostra mission aziendale è offrire prodotti che rappresentino soluzioni che possano esprimere e proiettare sulla porta e sulla casa la personalità di chi vi abita.

Un catalogo di nove collezioni, che rappresentano la cultura del legno, materiale nobile per eccellenza e la ricerca del design contemporaneo.

Tutte le porte Michelsoni sono prodotte interamente in Italia.

Chi acquista una porta in legno massello Michelsoni Porte ha la sicurezza che esse siano prodotte con tecnologie che rispettano l'ambiente. Utilizziamo solo materie prime eccellenti e sicure, garantendo le migliori condizioni di lavoro possibile.

L'Azienda si impegna a comunicare con chiarezza l'origine dei prodotti ed è per questi motivi che "Made in Italy" e "Made in Michelsoni Porte", sono espressione di valori forti come: stile innovativo, design originale, ma anche attenzione per l'ambiente, etica del lavoro e qualità del prodotto.

Le porte in legno massello Michelsoni creano eccellenze vere del Made in Italy.



COLLEZIONE
CLASSICA



PUNTA ALA
CIECA BUGNATA
SESTO RIBASSATO
TOULIPIER BASE



PUNTA ALA VETRO
BUGNATA VETRO VS-06
SESTO RIBASSATO
TOULIPIER BASE

GENOVA
CIECA BUGNATA
SESTO RIBASSATO
TOULIPIER BASE



GENOVA VETRO
VETRO BUGNATA
SESTO RIBASSATO
TOULIPIER BASE



GENOVA VETRO
BUGNATA VETRO VP-16
SESTO RIBASSATO
TOULIPIER BASE





VIAREGGIO
CIECA BUGNATA
TOULIPIER MEDIO



Toulipier

Il Toulipier Legno importato dalle regioni del sud America, ha un colore chiaro con sfumature verdastre.

Questo legno è particolarmente apprezzato per l'ottima reazione ai trattamenti con vernici, mordenti e impregnanti, mentre il colore chiaro e la compattezza della venatura permettono di riprodurre fedelmente altre essenze a poro chiuso; queste caratteristiche lo rendono un ottimo legno per la creazione di porte da interni.

VIAREGGIO VETRO
VETRO BUGNATA
TOULIPIER MEDIO



LIVORNO
CIECA BUGNATA
TOULIPIER MEDIO



LIVORNO VETRO
VETRO
TOULIPIER MEDIO



Semplicemente
Classico

VOLTERRA
CIECA BUGNATA
TOULPIERMEDIO





CIMASA C1 / COPRIFILO BLM

Effetto Invecchiato

La porta per chi ama la tradizione
e gli arredi dal sapore antico.

L'effetto della linea invecchiata è realizzato dalla straordinaria manualità di esperti artigiani, che donano alla porta il fascino del vissuto, conservando le caratteristiche della qualità del legno massello. Le sapienti mani creano effetti che solo il tempo e il colore del legno possono realizzare.



CERTALDO
CIECA BUGNATA
TOULIPIER MEDIO
EFFETTO INVECCHIATO



PORTE
DALL'ASPETTO
VISSUTO CON
FORMESCOLPITE
NEL LEGNO
E CONTRASTI IN
SUPERFICIE.



PUNTA ALA
CIECA BUGNATA
TIGLIO MEDIO



PUNTA ALA VETRO
VETRO BUGNATA
DOPPIA ANTA
TIGLIO MEDIO

Modello doppia anta

Il modello doppia anta è la soluzione ottimale per dividere due spazi senza dover murare, dando un aspetto più spazioso. Per non rinunciare ad un ambiente luminoso invece basterà scegliere la versione a vetro, che farà filtrare nell'ambiente la luce naturale del giorno.



MONTALCINO
CIECA BUGNATA
TIGLIO MEDIO



CERTALDO
CIECA BUGNATA
TIGLIO MEDIO



CORTE
CIECA BUGNATA
TIGLIO MEDIO



CORTE VETRO
VETRO VP-02
TIGLIO MEDIO





FIRENZE
CIECA BUGNATA
TIGLIO BASE



CERTALDO
CIECA BUGNATA
TIGLIO BASE

Tiglio

Legno importato dalle regioni del Nord Europa con buone caratteristiche di stabilità e dalla fibratura dritta con tessitura fine che si lascia lavorare facilmente rendendolo malleabile nelle mani dei nostri esperti artigiani.

Oggi è molto richiesto per il suo aspetto gradevole, indubbiamente uno dei legni con il miglior rapporto qualità/prezzo.

RAPALLO
CIECA BUGNATA
TIGLIO BASE

RAPALLO VETRO
VETRO BUGNATA
TIGLIO BASE



CHIAVARI
CIECA BUGNATA
TIGLIO BASE



CHIAVARI VETRO
VETRO BUGNATA
TIGLIO BASE



FORME SCOLPITE
NEL LEGNO PIÙ
PREGIATO DA
ESPERTI ARTIGIANI.



VERSILIA VETRO
8 VETRI BUGNATA
TIGLIO BASE

Porta a Vetro benefici e luce.

La luce, in una casa, è uno degli aspetti più importanti. La porta a vetro rende possibile il passaggio della luce anche a porta chiusa e questo la rende il modello perfetto per gli ambienti poco luminosi.

SIENA VETRO
8 VETRI
TIGLIO BASE



SIENA VETRO
12 VETRI
TIGLIO BASE



FIESOLE VETRO
VETRO
TIGLIO BASE



VERSILIA VETRO
6 VETRI BUGNATA
TIGLIO BASE

PORTE
MICHELONI
LO STILE
CLASSICO
AL PASSO
CON I TEMPI.





MONTALCINO
CIECA BUGNATA
ROVERE BASE



CERTALDO
CIECA BUGNATA
ROVERE BASE



FIRENZE
CIECA BUGNATA
ROVERE BASE

PUNTA ALA
CIECA BUGNATA
ROVERE BASE

PUNTA ALA VETRO
VETRO BUGNATA
ROVERE BASE





Rovere

Legno europeo, per la sua ottima resistenza è molto usato per infissi e serramenti per esterni, la fibra e le sue sfumature di colore possono variare a seconda della regione di provenienza. Esso è un legno che si lavora con facilità e che resiste alle peggiori situazioni climatiche ed all'usura; con il castagno è senza dubbio uno dei legni più pregiati ed utilizzati nella realizzazione di porte in legno massello di qualità e che durino nel tempo.

CORTE VETRO
VETRO VS-03
ROVERE MIELE



SATURNIA
CIECA
ROVERE MIELE



SATURNIA VETRO
VETRO VS-SA-01
ROVERE MIELE



CORTE
CIECA BUGNATA
ROVERE MIELE





PUNTA ALA
CIECA BUGNATA
SESTO RIBASSATO
CASTAGNO BASE



Castagno

Legno europeo di colore bruno chiaro, molto durevole e resistente, ha una venatura molto accentuata che può variare dal fiammato al rigato. Molto buona è anche la sua durabilità, viene impiegato come legno da costruzione per interni ed esterni, è infatti uno dei legni più pregiati ed utilizzati nell'arredamento.



PUNTA ALA VETRO
VETRO BUGNATA
SESTO RIBASSATO
CASTAGNO BASE



CORTE VETRO
VETRO VS-16
SESTO RIBASSATO
CASTAGNO BASE



SATURNIA VETRO
VETRO CON SOPRALUCE
CASTAGNO BASE

SATURNIA VETRO
VETRO VS-SA-01
CASTAGNO BASE



SATURNIA
CIECA
CASTAGNO BASE



SAVONA VETRO
VETRO CENTRALE
BUGNATA
CASTAGNO BASE



SAVONA VETRO
VETRO BUGNATA
CASTAGNO BASE



NUOVE FORME
IMPRESSE NEL
LEGNO, FINITURE
DAL FASCINO
ESCLUSIVO.



FIRENZE
CIECA BUGNATA
FRASSINO BASE



FIRENZE VETRO
VETROCENTRALE BUGNATA
FRASSINO BASE



MONTALCINO
CIECA BUGNATA
FRASSINO BASE



PUNTA ALA VETRO
VETRO VS-13 BUGNATA
FRASSINO BASE



PUNTA ALA
CIECA BUGNATA
FRASSINO BASE

CERTALDO
CIECA BUGNATA
FRASSINO BASE



Frassino

Un legno europeo, spesso usato per le caratteristiche di resistenza, come alternativa più economica al castagno, soprattutto le parti più scure, dette olivate, sono molto somiglianti.

Il Frassino è un legno alla fibra compatta e resistente che si leviga e si vernicia bene, è tenace ed elastico, per questo molto apprezzato dai costruttori di mobili.

CERTALDO VETRO
VETRO CENTRALE BUGNATA
FRASSINO BASE



CORTE
CIECA BUGNATA
FRASSINO BASE





MONTALCINO
CIECA BUGNATA
PINO ARTE POVERA



MONTALCINO VETRO
VETRO VS-02
PINO ARTE POVERA

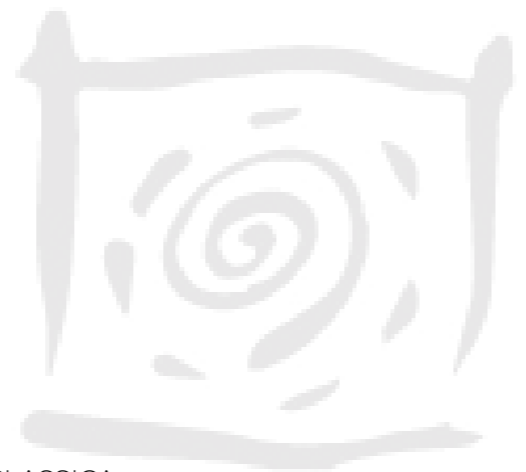
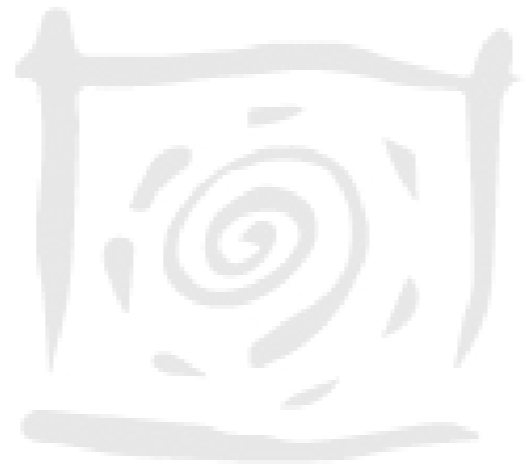

PUNTA ALA
CIECA BUGNATA
PINO ARTE POVERA



PUNTA ALA VETRO
VETRO BUGNATA
PINO ARTE POVERA

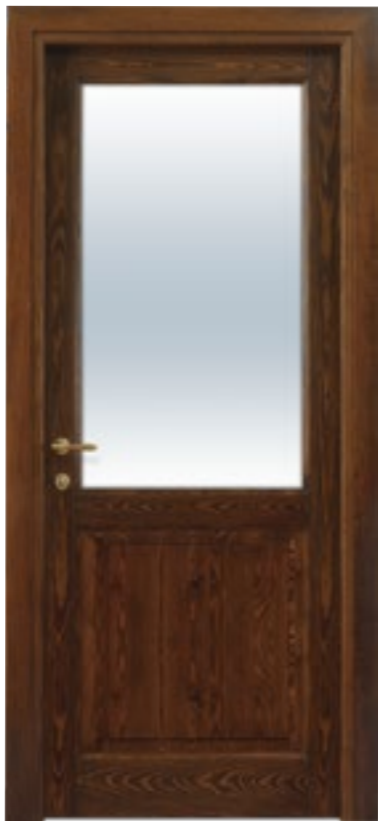

CERTALDO
CIECA BUGNATA
PINO ARTE POVERA





GENOVA VETRO
VETRO BUGNATA
PINO ARTE POVERA



GENOVA
BUGNATA
PINO ARTE POVERA

Pino

Legno di provenienza Nord Europa, è il legno maggiormente usato per infissi esterni in Italia. Ha discrete caratteristiche di stabilità dimensionale, lavorabilità e durabilità. La sua venatura è molto accentuata può variare dal fiammato al rigato, la differenza cromatica tra alburno e durame, che si accentua con il tempo, causa dell'elevata nodosità che rende questo legno perfetto per conferire un carattere rustico





CIMASA C1 / COPRIFILO LM

Spazzolato Rustico I colori che solo la natura può donare

Le forme scolpite nel legno e i contrasti di superficie danno alla porta un aspetto vissuto.

Le lavorazioni di spazzolatura effetto rustico effettuate rigorosamente a mano rendono la porta un modello unico dal tocco inimitabile, per un prodotto dallo stile inconfondibile.

Adatta ad ambienti che richiamano la tradizione e la bellezza dei casolari antichi.

CERTALDO
CIECA BUGNATA
PINO ARTE POVERA
SPAZZOLATO RUSTICO



PUNTA ALA
CIECA BUGNATA
PINO ARTE POVERA
SPAZZOLATO RUSTICO



Decora la **Porta Laccata** con eleganza e raffinatezza con i **nuovi decori** Micheloni Porte, studiati per rendere ogni modello unico e ricercato. Scegli tra 13 DECORI e 4 TEXTURE esclusivi per personalizzare al meglio la tua porta!

CERTALDO
CIECA BUGNATA
TIGLIO LACCATO ANTICATO
DECORO D01



CERTALDO
CIECA BUGNATA
TIGLIO LACCATO ANTICATO
DECORO D02



CERTALDO
CIECA BUGNATA
TIGLIO LACCATO ANTICATO
DECORO D03



CERTALDO
CIECA BUGNATA
TIGLIO LACCATO ANTICATO
DECORO D04

CORTE
CIECA BUGNATA
TIGLIO LACCATO ANTICATO
DECORO D07



PUNTA ALA
CIECA BUGNATA
TIGLIO LACCATO ANTICATO
DECORO D09



FIRENZE
CIECA BUGNATA
TIGLIO LACCATO ANTICATO
DECORO D10



DECORI MODELLI LACCATI - COLLEZIONE CLASSICA

DECORO D01

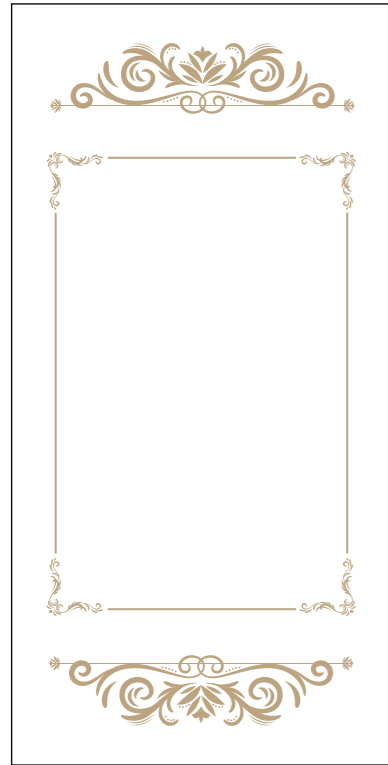

DECORO D02

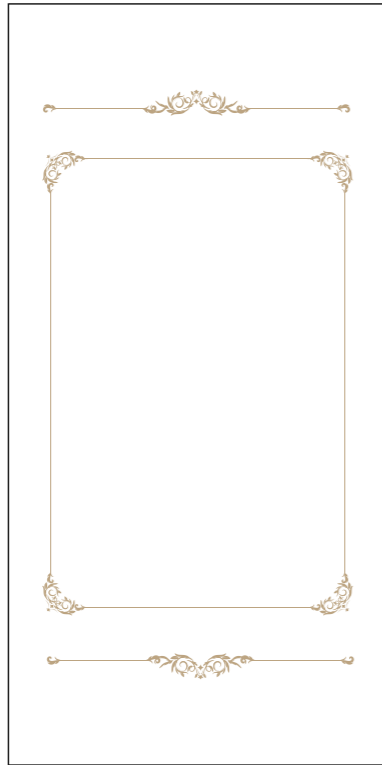

DECORO D03

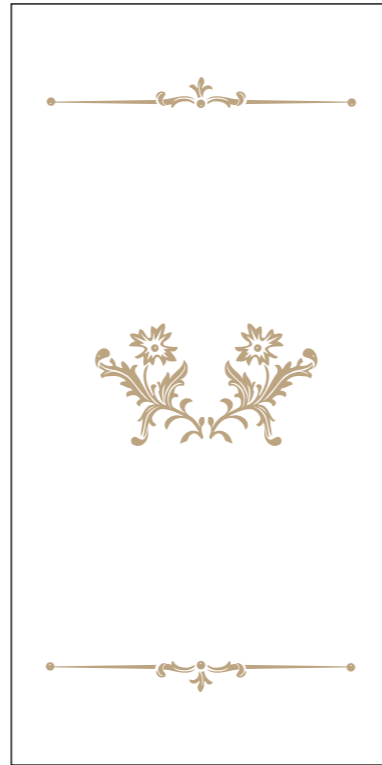

DECORO D04



DECORO D05

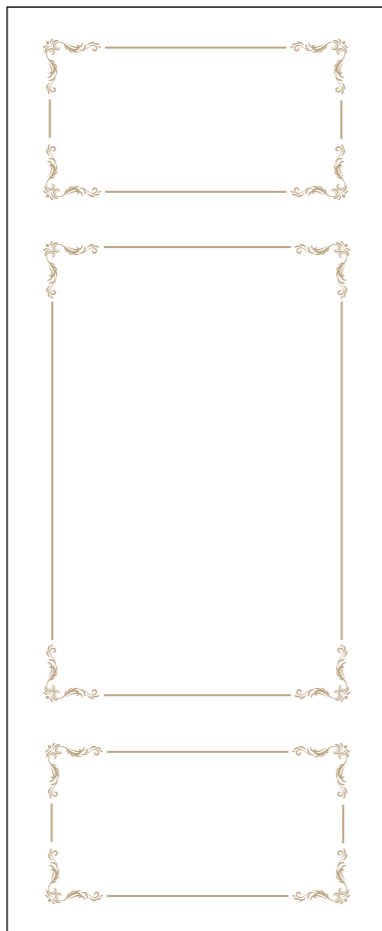

DECORO D06



DECORO D07

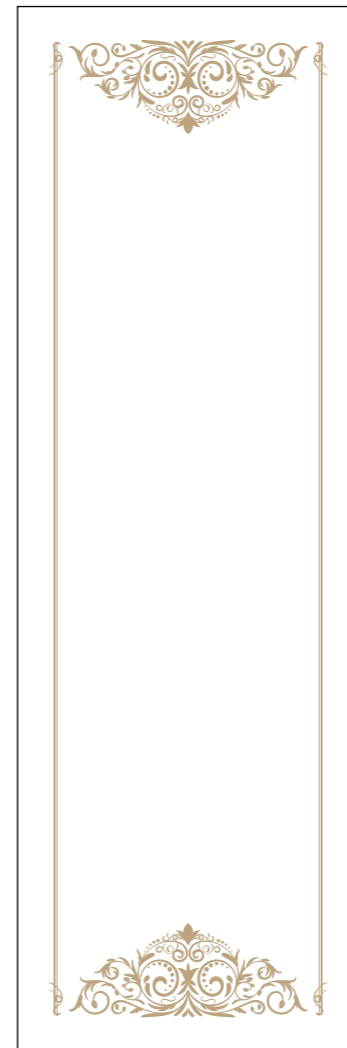

DECORO D08



DECORO D10



DECORO D11

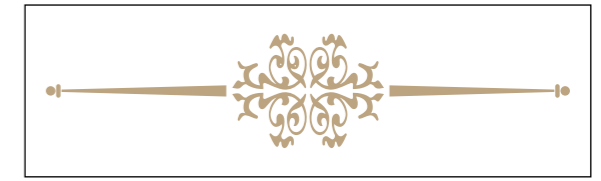

DECORO D09

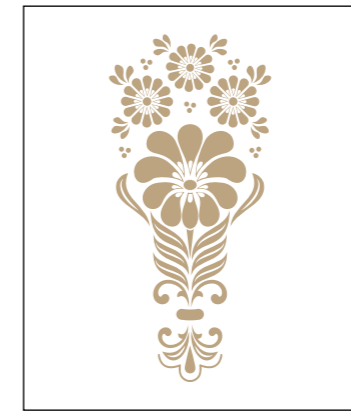

DECORO D12



DECORO D13



N.B.: Tutti i decori sono riproducibili su tutti i modelli di porta della collezione Classica previa approvazione dell'azienda.

SCEGLI LA TEXTURE DEL TUO DECORO:

TEXTURE B



TEXTURE V



TEXTURE O



TEXTURE R





COLLEZIONE

CLASSICA SLIDE



ARREDA LA TUA CASA CON LO STILE MICHELONI



MONTALCINO
CIECA SLIDE
FRASSINO
NATURALE BIANCO
SPAZZOLATO

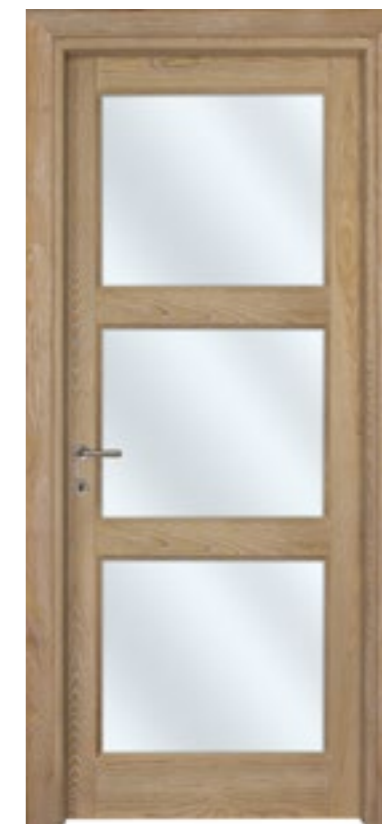

MONTALCINO VETRO
VETRO
FRASSINO
NATURALE BIANCO
SPAZZOLATO



CERTALDO
CIECA SLIDE
FRASSINO
NATURALE BIANCO
SPAZZOLATO



CERTALDO VETRO
VETRO SLIDE
FRASSINO
NATURALE BIANCO
SPAZZOLATO



CORTE
CIECA SLIDE
FRASSINO
NATURALE BIANCO
SPAZZOLATO



PUNTA ALA
CIECA SLIDE
FRASSINO
NATURALE BIANCO
SPAZZOLATO



PUNTA ALA VETRO
VETRO SLIDE
FRASSINO
NATURALE BIANCO
SPAZZOLATO



FIRENZE VETRO
VETRO CENTRALE SLIDE
FRASSINO
NATURALE BIANCO
SPAZZOLATO



FIRENZE
CIECA SLIDE
FRASSINO
NATURALE BIANCO
SPAZZOLATO



A modern living room with a large window, a wooden coffee table, a sofa, and a cowhide rug. The room features a large window with a view of a landscape, a wooden coffee table, a sofa with white cushions and patterned pillows, and a cowhide rug on the floor. A large, textured pendant light hangs from the ceiling. The text "LA PORTA PERFETTA, SINTESI TRA CLASSICO E MODERNO." is overlaid on the window area.

LA PORTA
PERFETTA,
SINTESI TRA
CLASSICO E
MODERNO.



PUNTA ALA
CIECA SLIDE
CASTAGNO MEDIO



CORTE
CIECA SLIDE
CASTAGNO MEDIO



FIRENZE
CIECA SLIDE
CASTAGNO MEDIO



FIRENZE VETRO
VETRO CENTRALE SLIDE
CASTAGNO MEDIO

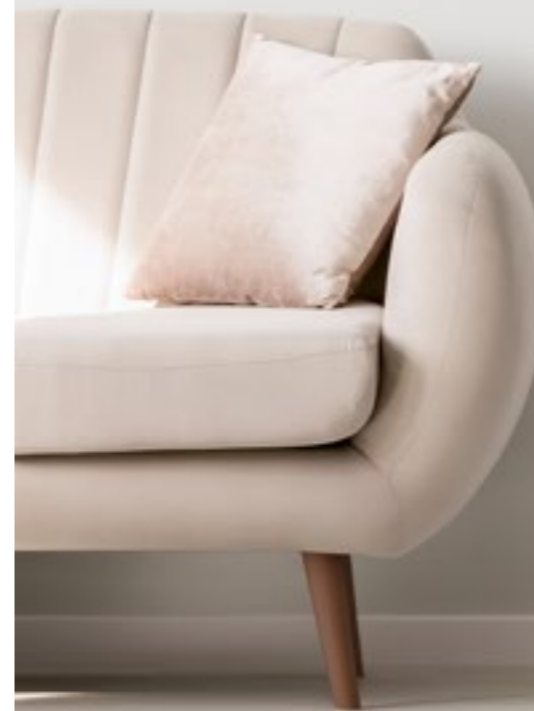

CERTALDO
CIECA SLIDE
CASTAGNO MEDIO



MONTALCINO
CIECA SLIDE
CASTAGNO MEDIO



MONTALCINO VETRO
VETRO SLIDE
CASTAGNO MEDIO



SOLIDITÀ E
ROBUSTEZZA
GLI IMMANCABILI
VALORI ALLA
BASE DELLE
PORTEMICHELONI.





COLLEZIONE
MILLENIUM



MONTALCINO
CIECA BUGNATA
TOULIPIER MEDIO



MONTALCINO VETRO
VETRO
TOULIPIER MEDIO



Eleganza senza tempo

PUNTA ALA
CIECA BUGNATA
TOULIPIER MEDIO



PUNTA ALA VETRO
VETRO BUGNATA
TOULIPIER MEDIO



CORTE
CIECA BUGNATA
TOULIPIER MEDIO



A rustic living room with a dark wood bookshelf filled with books and decorative objects. In the foreground, a brown leather tufted sofa is positioned on a light-colored rug with a geometric pattern. A round, dark coffee table sits in front of the sofa. The overall aesthetic is warm and traditional.

LA PORTA
PER CHI AMA
LA TRADIZIONE
E GLI ARREDI
DAL SAPORE
ANTICO.



GENOVA
CIECA BUGNATA
CASTAGNO
NATURALE BIANCO

CERTALDO
CIECA BUGNATA
CASTAGNO
NATURALE BIANCO

CERTALDO VETRO
VETRO
CASTAGNO
NATURALE BIANCO

GENOVA VETRO
VETRO BUGNATA
CASTAGNO
NATURALE BIANCO





PUNTA ALA
CIECA BUGNATA
CASTAGNO
NATURALE BIANCO



PUNTA ALA VETRO
VETRO BUGNATA
CASTAGNO
NATURALE BIANCO



CORTE
CIECA BUGNATA
CASTAGNO
NATURALE BIANCO



CORTE VETRO
VETRO VS-04
CASTAGNO
NATURALE BIANCO





CALORE DEL
LEGNO E
PREZIOSE
LAVORAZIONI,
PER UNA PORTA
SEMPLICEMENTE
UNICA ED
ELEGANTE.



COLLEZIONE
MODERNA



TIME
FRASSINO
SPAZZOLATO
LACCATO RAL1013



TIME - IN LINEA
CIECA
FRASSINO SPAZZOLATO
LACCATO RAL1013



TIME IV
FRASSINO VP-19
SPAZZOLATO
LACCATO RAL1013



DREAM IV
FRASSINO VP-19
SPAZZOLATO
LACCATO RAL1013



FINITURA SPAZZOLATA LACCATA

L'effetto spazzolato risponde alle tendenze contemporanee offrendo una porta laccata disponibile in tutte le colorazioni dei codici ral. Questa lavorazione dona al prodotto una sorta di movimento in grado di caratterizzare gli ambienti circostanti siano essi estremamente moderni oppure più tradizionali.

TIME 4V

CIECA CON VETRO
FRASSINO SPAZZOLATO
LACCATO RAL1013



TIME 3V

CIECA CON VETRO
FRASSINO SPAZZOLATO
LACCATO RAL1013



TIME 2V/C

CIECA CON VETRO
FRASSINO SPAZZOLATO
LACCATO RAL1013



TIME 2V
CIECA CON VETRO
FRASSINO SPAZZOLATO
LACCATO RAL1013



MAGIC 1B
 CIECA CON BISELLATURA
 FRASSINO LACCATO
 NERO PORO APERTO



“ FINITURA LACCATA PORO APERTO ”

La raffinata linea di una porta di design trova la sua perfezione nelle finiture laccate a poro aperto mantenendo il piacere al tatto delle venature del legno. Il design più moderno o la concretezza dell'eleganza per le vostre porte per interni non scendete a compromessi. Una finitura apprezzata dai più importanti brand dell'arredo casa.

MAGIC 3B
 CIECA CON BISELLATURA
 FRASSINO LACCATO NERO
 PORO APERTO



MAGIC
 CIECA CON BISELLATURA
 FRASSINO LACCATO NERO
 PORO APERTO



DREAM 1V
 VETRO
 FRASSINO LACCATO
 NERO PORO APERTO





LA GEOMETRIA
DEL DESIGN
PER UN'ELEGANZA
SENZA
COMPROMESSI

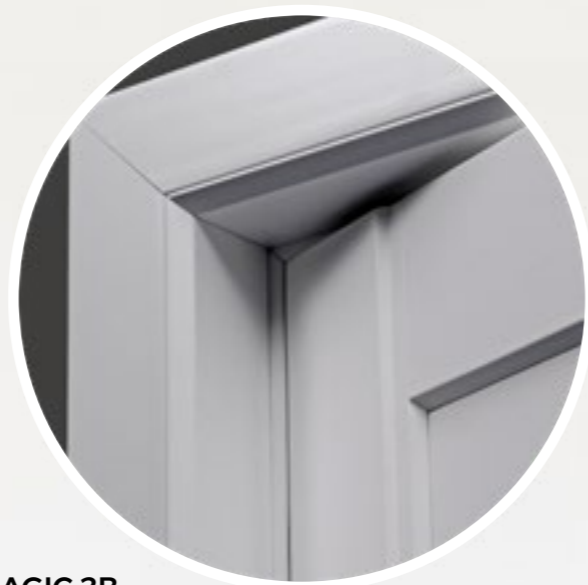

MAGIC 2B
CIECA CON BISELLATURA
TOULIPIER
LACCATO BIANCO
VISTA INTERNA



MAGIC 2B
CIECA CON BISELLATURA
TOULIPIER
LACCATO BIANCO
VISTA ESTERNA





TIME - IN LINEA
CIECA
TOULPIER
LACCATO BIANCO



DREAM 1V
VETRO VS-12
TOULPIER
LACCATO BIANCO

TIME 1V - IN LINEA
CIECA CON VETRO
TOULPIER
LACCATO BIANCO



TIME 2V/C - IN LINEA
CIECA CON VETRO
TOULPIER
LACCATO BIANCO



TIME 3V - IN LINEA
CIECA CON VETRO
TOULPIER
LACCATO BIANCO



LE LINEE ESSENZIALI ED I CONTRASTI DELLE VENATURE, CREANO UNA SINTESI PERFETTA TRA LA MODERNITÀ DEL DESIGN E LA QUALITÀ DEL VERO LEGNO MASSELLO.

MAGIC
CIECA CON BISELLATURA
TOULIPIER MEDIO



MAGIC 2B
CIECA CON BISELLATURA
TOULIPIER MEDIO



MAGIC 2B/C
CIECA CON BISELLATURA
TOULIPIER MEDIO



MAGIC 3B
CIECA CON BISELLATURA
TOULIPIER MEDIO





TIME
CIECA
ROVERE BASE
VISTA INTERNA



TIME
CIECA
ROVERE BASE
VISTA ESTERNA



TIME IV
CIECA CON VETRO
ROVERE BASE



CERNIERE A SCOMPARSA E SERRATURA MAGNETICA

La porta è dotata di serie, delle cerniere a scomparsa regolabili su tre assi e della serratura magnetica. La collezione moderna offre anche numerose possibilità di personalizzazioni e di finiture.

DREAM IT
VETRO
ROVERE BASE



DREAM IV
VETRO
ROVERE BASE





TIME 2V/C
CIECA CON VETRO
ROVERE SCURO



TIME 2V
CIECA CON VETRO
ROVERE SCURO



DESIGN
MODERNO ED
INNOVATIVO
PER UN
ARREDAMENTO
AL PASSO
CON I TEMPI



TIME 3V
CIECA CON VETRO
ROVERE SCURO





COLLEZIONE

NEW LINE

SPACE 2 IN V
CIECA CON VETRO
FRASSINO
LACCATO BIANCO
PORO APERTO

SPACE
CIECA
FRASSINO
LACCATO BIANCO
PORO APERTO



SPACE 2 IN
CIECA CON INCISIONI
FRASSINO
LACCATO BIANCO
PORO APERTO



SPACE 2 AL
CIECA CON INERTI IN ALLUMINIO
FRASSINO
LACCATO BIANCO
PORO APERTO



SPACE 1V
VETRO VP-13
FRASSINO
LACCATO BIANCO
PORO APERTO





SPACE 4 IN V
CIECA CON VETRO
CASTAGNO
NATURALE BIANCO



SPACE 4 IN
CIECA CON INCISIONI
CASTAGNO
NATURALE BIANCO

SPACE 1V
VETRO VS-09
CASTAGNO
NATURALE BIANCO



SPACE 6 IN V
CIECA CON VETRO
CASTAGNO
NATURALE BIANCO



SPACE 6 IN
CIECA CON INCISIONI
CASTAGNO
NATURALE BIANCO



SPACE
CIECA
CASTAGNO
NATURALE BIANCO

PORTE COMPATTE
E ROBUSTE
COSTRUITE CON
MAESTRIA E CURA
ARTIGIANALE.



SPACE 2 AL
CIECA CON INSERTI
IN ALLUMINIO
ROVERE MEDIO



SPACE
CIECA
ROVERE MEDIO



SPACE 1 V
VETRO
ROVERE MEDIO

SPACE 4 IN
CIECA CON INCISIONI
ROVERE MEDIO



SPACE 4 AL
CIECA CON INERTI IN ALLUMINIO
ROVERE MEDIO



SPACE 2 IN
CIECA CON INCISIONI
ROVERE MEDIO



DAI CARATTERE
ALLA PORTA
CON GLI INSERTI
IN ALLUMINIO
DI MICHELONI PORTE



SPACE IV
VETRO
TIGLIO BASE

SPACE
CIECA
TIGLIO BASE





SPACE 4 AL
CIECA CON INERTI IN ALLUMINIO
TIGLIO BASE



SPACE 6 IN
CIECA CON INCISIONI
TIGLIO BASE



SPACE 6 AL
CIECA CON INERTI IN ALLUMINIO
TIGLIO BASE



SPACE 4 IN
CIECA CON INCISIONI
TIGLIO BASE



COLLEZIONE
CUBICA



LINEA
CIECA
CASTAGNO
NATURALE BIANCO



QUADRA
CIECA
CASTAGNO
NATURALE BIANCO



FORMA
CIECA
CASTAGNO
NATURALE BIANCO



FORMA VETRO
VETRO
CASTAGNO
NATURALE BIANCO







QUATTRO ESSE
CIECA
TOULIPIER CHIARO



QUADRA
CIECA
TOULIPIER CHIARO



QUADRA VETRO
VETRO
TOULIPIER CHIARO



TRE ESSE
CIECA
TOULIPIER CHIARO

FORMA
CIECA
TOULIPIER BASE

FORMA VETRO
VETRO
TOULIPIER BASE





QUADRA
CIECA
TOULIPIER BASE



LINEA
CIECA
TOULIPIER BASE



LINEA VETRO
VETRO
TOULIPIER BASE





QUATTRO ESSE
CIECA
TIGLIO BASE

UNO ESSE VETRO
VETRO
TIGLIO CHIARO



UNO ESSE
CIECA
TIGLIO CHIARO



DUE ESSE
CIECA
TIGLIO CHIARO



QUALITÀ DEI
MATERIALI E
DESIGN LINEARE
PER UNA PORTA
DALLA FORTE
PERSONALITÀ.





COLLEZIONE
STYLE

LOGICA 4P
CIECA LISCIA
TOULPIER MEDIO



LOGICA 3P/C
CIECA LISCIA
TOULPIER MEDIO



LOGICA 3V/C
VETRO
TOULPIER MEDIO

LOGICA 4V
VETRO
TOULPIER MEDIO



LOGICA 3P
CIECA LISCIA
TOULPIER MEDIO



LOGICA 3V
VETRO
TOULPIER MEDIO



SCEGLI
L'ELEGANZA
DI UNA PORTA
ITALIAN STYLE.





LOGICA 3P
CIECA LISCIA
TIGLIO BASE



SCEGLI LA
COLLEZIONE
STYLE, SOBRIA
ED ELEGANTE.





LOGICA
CIECA LISCIA
ROVERE BASE



LOGICA IV
VETRO
ROVERE BASE



LOGICA 3P
CIECA LISCIA
ROVERE BASE



LOGICA 3P/C
CIECA LISCIA
ROVERE BASE



LOGICA 2P
CIECA LISCIA
FRASSINO MEDIO



LOGICA 4P
CIECA LISCIA
FRASSINO MEDIO



LOGICA 4V
VETRO
FRASSINO MEDIO

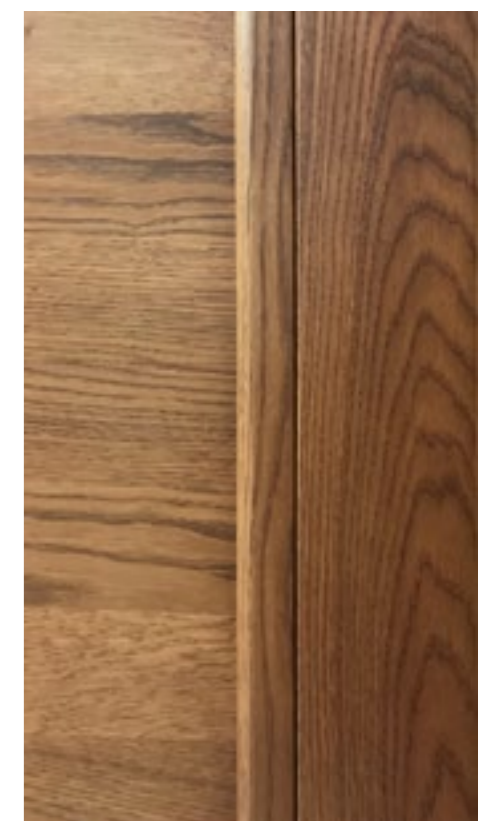

LOGICA 2V
VETRO
FRASSINO MEDIO



LOGICA
CIECA LISCIA
FRASSINO MEDIO



LOGICA 1V
VETRO
FRASSINO MEDIO



PER UN PERFETTO
URBAN STYLE



COLLEZIONE

LINEAR E
LINEAR BUGNATA





FIESOLE
CIECA LISCIA
TOULIPIER MEDIO



GENOVA VETRO
VETRO LISCIA
TOULIPIER MEDIO

GENOVA
CIECA LISCIA
TOULIPIER MEDIO

FIESOLE VETRO
VETRO
TOULIPIER MEDIO



PERSONALIZZA
GLI AMBIENTI
DELLA TUA CASA



PUNTA ALA
CIECA LISCIA
TIGLIO BASE



PUNTA ALA VETRO
VETRO VP-04 LISCIA
TIGLIO BASE



CORTE VETRO
VETRO
TIGLIO BASE



CORTE
CIECA LISCIA
TIGLIO BASE

FIRENZE
CIECA LISCIA
TIGLIO BASE



FIRENZE VETRO
VETRO LISCIA
TIGLIO BASE



FIRENZE VETRO
VETRO LISCIA
TIGLIO BASE







MONTALCINO VETRO
VETRO
TIGLIO MEDIO

CERTALDO
CIECA LISCIA
TIGLIO MEDIO



CERTALDO VETRO
VETRO LISCIA
TIGLIO MEDIO



CERTALDO VETRO
VETRO LISCIA
TIGLIO MEDIO



MONTALCINO
CIECA LISCIA
TIGLIO MEDIO





CERTALDO
CIECA LISCIA
FRASSINO BASE



CERTALDO VETRO
VETRO LISCIA
FRASSINO BASE



PUNTA ALA
CIECA LISCIA
FRASSINO BASE



PUNTA ALA VETRO
VETRO LISCIA
FRASSINO BASE



RICHIAMA I COLORI
DELLA NATURA CON
PORTE IN VERO
LEGNO MASSELLO





GENOVA
CIECA BUGNATA
TIGLIO MEDIO



GENOVA VETRO
VETRO VP-20 BUGNATA
TIGLIO MEDIO



PUNTA ALA
VETRO BUGNATA
TIGLIO MEDIO



PUNTA ALA
CIECA BUGNATA
TIGLIO MEDIO



CERTALDO
CIECA BUGNATA
TIGLIO MEDIO



CERTALDO VETRO
VETRO BUGNATA
TIGLIO MEDIO



MONTALCINO VETRO
VETRO
TIGLIO MEDIO



MONTALCINO
CIECA BUGNATA
TIGLIO MEDIO



SOLUZIONI D'ARREDAMENTO

100% MADE IN ITALY • 100% MICHELONI PORTE

Ogni persona desidera rendere la propria casa unica e personale, che rispecchi al 100% la propria personalità. Micheloni Porte, grazie alla realizzazione delle porte in maniera artigiana, rende possibile la scelta e la composizione degli elementi della porta senza doversi accontentare di un modello standard.

Essendo la porta un complemento d'arredo esistono diversi modi per rendere le porte di casa personali e uniche. Oltre alla scelta del modello, telai e coprifili, l'essenza del legno e la finitura, Micheloni Porte da la possibilità di scegliere il senso ed il sistema di apertura della porta, rendere la porta ancora più moderna con i modelli in linea e raso parete e anche creare il rivestimento per la porta blindata per una personalizzazione a 360°.

PORTA BATTENTE • PORTA SCORREVOLE INTERNO MURO • PORTA ROTOTRASLANTE • PORTA PIEGHEVOLE • PORTA SCORREVOLE ESTERNO MURO • RIVESTIMENTO PORTE BLINDATE • PORTA A LIBRO • PORTA A VETRO • PORTA CIECA • VETRI DECORATI • VETRI CON STAMPA DIGITALE • VETRI INCISI • VETRI SATINATI • VETRI SABBATI • ACCESSORI FERRAMENTA • CERNIERE A SCOMPARSA • PORTA IN LINEA • PORTA RASO PARETE • PORTA FILO MURO • SERRATURA MAGNETICA • SESTO RIBASSATO • TELAI COPRIFILI • ESSENZE • FINITURE • PINO • FRASSINO • CASTAGNO • TIGLIO • TOULUPIER • ROVERE • LEGNO MASSELLO • CIMASE • Basette • Lesene • Capitelli • PORTE FUORI MISURA • PORTA DOPPIA ANTA • PORTA TIPO SALOON VA E VIENE • PORTA PIEGHEVOLE ASIMMETRICA • PORTA PIEGHEVOLE SIMMETRICA • PORTA SU TELAIO A CHIAMBRANA • PORTA CON SOPRALUCE • PORTA DUE ANTE SOVRAPPOSTE • PORTA DECORATA • TRAVERSO SUPERIORE CON SESTO RIBASSATO • PORTA LACCATA • PORTA LACCATA ANTICATA •



NOVITÀ

APERTURA ROTOTRASLANTE

50%
D'INGOMBRO
IN MENO

PORTA BATTENTE TRADIZIONALE
SINISTRA A SPINGERE

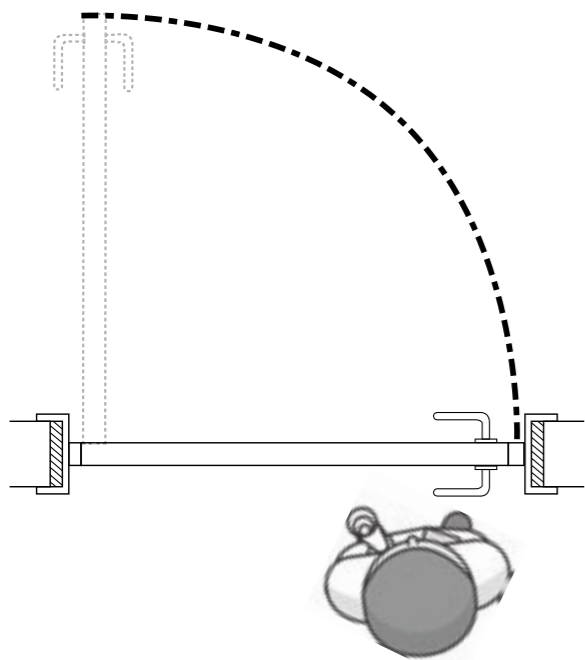

PORTA ROTOTRASLANTE
SINISTRA A SPINGERE

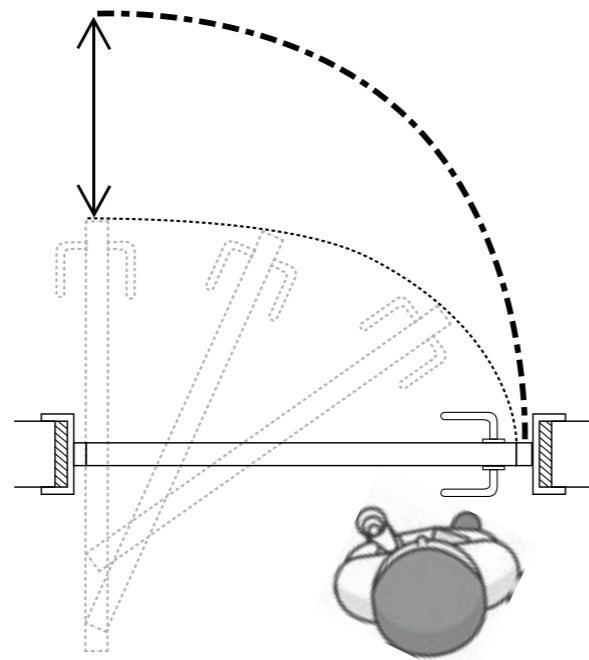

La novità della Porta Rototraslante

La porta rototraslante è la soluzione migliore in alternativa alla porta tradizionale, pieghevole o scorrevole perchè, nelle abitazioni spazi ristretti, costituisce un sistema rivoluzionario capace di ridurre gli ingombri e aumentare gli spazi.

Questo sistema di apertura alla vista si presenta analogo alle porte tradizionali, composte da un unico pannello perchè, quello che cambia è la modalità di apertura difatti, la particolarità risiede in un meccanismo che, durante l'apertura e la chiusura, permette all'anta di ruotare e traslare contemporaneamente. La grande differenza dal modello tradizionale, è che non è incernierata sul fianco, ma ruota su di un perno centrale che scorre lateralmente.





PORTA SCORREVOLE INTERNO MURO

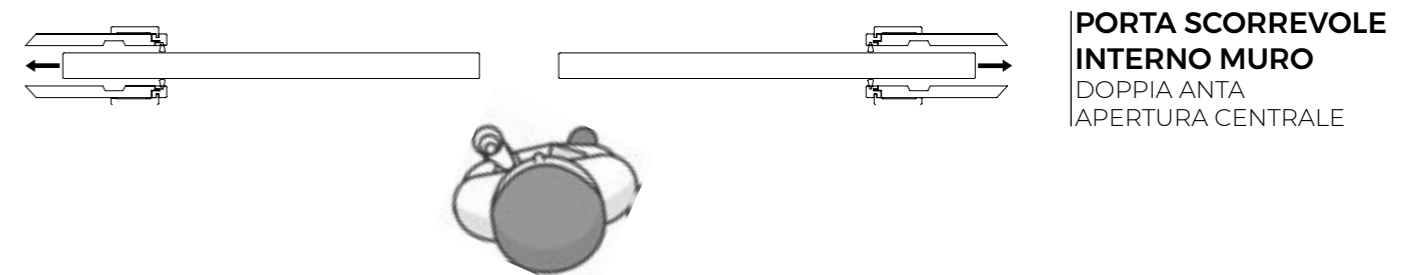
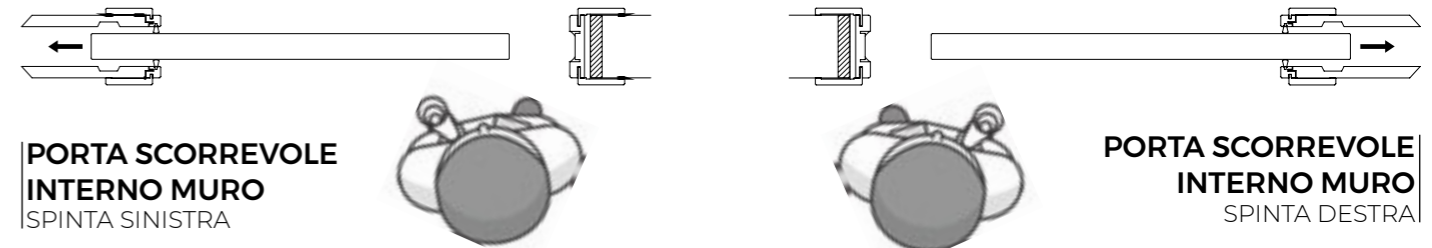

L'essenzialità della Porta Scorrevole Interno Muro

Le scorrevoli sono tra i sistemi di apertura più utilizzati, dopo la porta battente, perchè sono le porte ideali per chi ha spazi ridotti. In modo particolare la porta scorrevole interno muro è la soluzione migliore per salvare gli spazi della vostra casa perchè scompare nello spessore della parete, recuperando così lo spazio che è solitamente occupato dal raggio di apertura dalla tradizionale porta a battente.

Questo tipo di porta consente di avere una soluzione che libera completamente la parete dando così più pulizia estetica e dello spazio in più da arredare a piacimento.

PORTA SCORREVOLE ESTERNO MURO

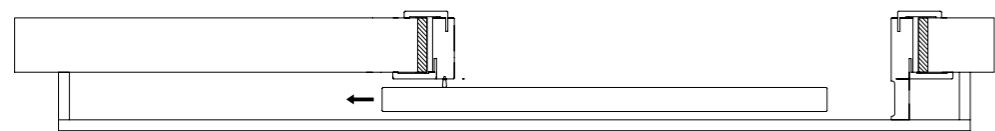

PORTA SCORREVOLE
ESTERNO MURO
CON MANTOVANA
SPINTA A SINISTRA



PORTA SCORREVOLE
ESTERNO MURO
CON MANTOVANA
SPINTA A DESTRA

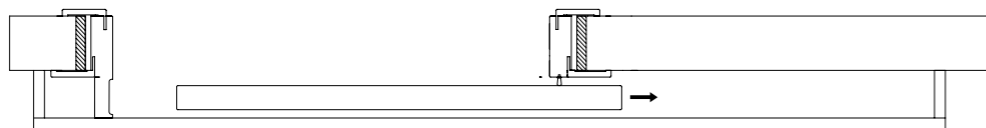

L'efficienza della Porta Scorrevole Interno Muro

La porta scorrevole esterno muro è una soluzione semplice e rapida, soprattutto se non si ha la possibilità di intervenire sulla muratura della casa perchè, l'anta non entra all'interno del muro ma scorre parallela ad esso grazie ad un binario. Quest'ultima è una soluzione molto apprezzata per rendere l'ambiente della propria casa più decorato e per dare un tocco di modernità.



PORTA PIEGHEVOLE SIMMETRICA

PIEGHEVOLE SIMMETRICA
SINISTRA A TIRARE

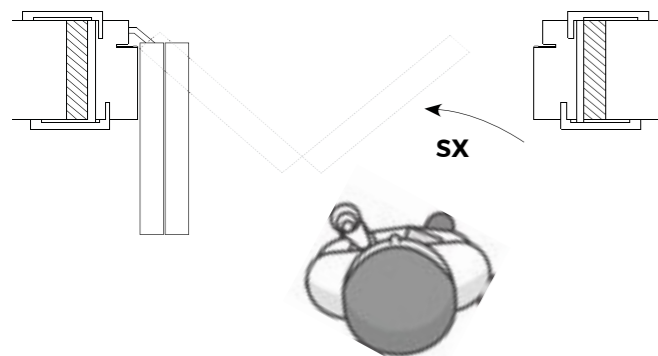

PIEGHEVOLE SIMMETRICA
SINISTRA A SPINGERE

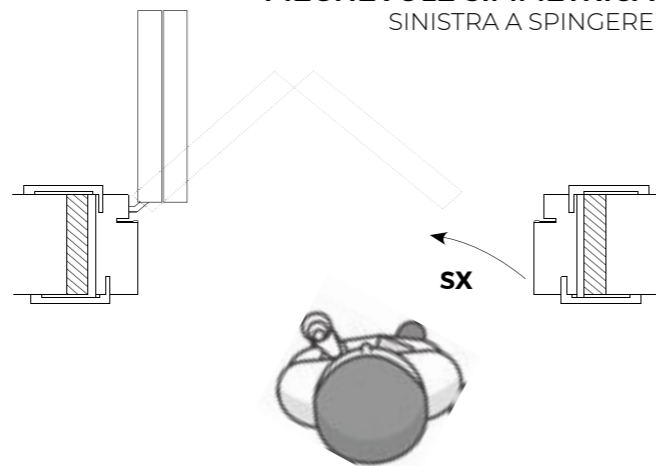

La praticità della Porta Pieghevole

Le porte pieghevoli o meglio conosciute come porte a libro, sono la soluzione migliore per gli ambienti ridotti, infatti l'anta della porta si piega "a libro" (da qui il nome) con rapporto tra le parti di 50 e 50 per le porte simmetriche e 2/3 e 1/3 per quelle asimmetriche, il tutto per occupare meno spazio possibile all'interno o all'esterno della stanza. Queste tipologie di apertura sono solitamente consigliate per vani piccoli ma che necessitano di spazio come bagni, ripostigli e locali di servizio, nulla però vieta di utilizzarle anche per camere da letto o corridoi.



MONTALCINO
CIECA BUGNATA
PIEGHEVOLE SIMMETRICA
APERTURA DESTRA A TIRARE
TIGLIO BASE



PUNTA ALA
CIECA BUGNATA
PIEGHEVOLE SIMMETRICA
APERTURA SINISTRA A TIRARE
CASTAGNO MEDIO

PORTA PIEGHEVOLE ASIMMETRICA



CERTALDO
CIECA BUGNATA
PIEGHEVOLE ASIMMETRICA
FRASSINO MEDIO

PIEGHEVOLE ASIMMETRICA
SINISTRA A SPINGERE

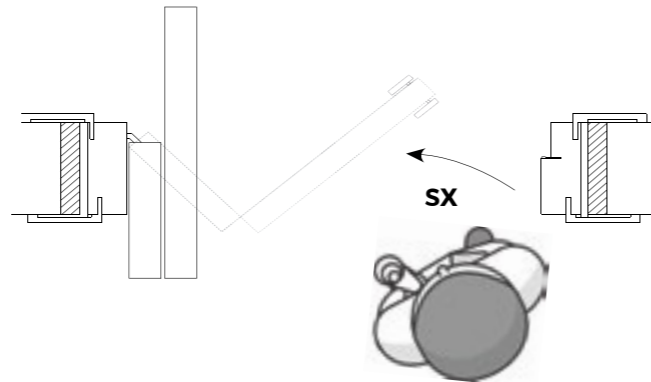

CORTE VETRO
VETRO MONTANTE CENTRALE
PIEGHEVOLE ASIMMETRICA
APERTURA DESTRA A SPINGERE
TOULIPIER MEDIO



CORTE VETRO
VETRO FILO LUCIDO
PIEGHEVOLE ASIMMETRICA
APERTURA DESTRA A SPINGERE
TOULIPIER MEDIO



CERTALDO
CIECA BUGNATA
PIEGHEVOLE ASIMMETRICA
APERTURA DESTRA A SPINGERE
FRASSINO MEDIO

SCOPRI LE PORTE "MINIMALI"

NON VUOI RINUNCIARE AL TELAIO E AI COPRIFILI? SCEGLI LA PORTA IN LINEA

La porta in linea, a differenza del modello sopra indicato, mantiene il classico telaio ed i coprifili ma rimane perfettamente a filo della parete riducendo l'ingombro della porta dando all'ambiente un aspetto visivo lineare e pulito.



L'ESTETICA MINIMALE DELLA PORTA RASOPARETE

La porta rasoparete si presenta senza stipite e senza coprifilo così da creare uno stile minimale e moderno, questa particolare soluzione è molto versatile perchè lega alla perfezione con l'architettura della casa.

Il modello di porta rasoparete può infatti mimetizzarsi, se non sparire, con la parete per legare meglio con l'ambiente oppure, utilizzando colori di contrasto, risaltare così da dare maggior carattere alla stanza.

P.S. Ogni modello di porta rasoparete è inoltre realizzabile su misura per la vostra casa: più alto, più basso o inclinato.

RIVESTIMENTI PER PORTE BLINDATE

Con i rivestimenti di Micheloni Porte puoi abbinare tutte le porte di casa al blindato senza doverlo cambiare per intero, infatti basterà solo sostituire il vecchio pannello interno con il pannello nuovo del brand Micheloni ed il gioco è fatto, tutte le porte di casa saranno in coordinato. Questa soluzione dà la possibilità di non dover rinunciare al modello di porta desiderato e mantenere lo stile della casa inalterato, da quello più classico a quello più moderno!





CIMASA C2
 BASETTA
 LESENA
 CAPITELLO



CIMASE, BASETTE, LESENE E CAPITELLI



CIMASA C1



CIMASA C2



CIMASA C3

TELAIE E COPRIFILI

TELAIO IN MASSELLO **MR10**
COPRIFILO IN MASSELLO **LM**



TELAIO IN LISTELLARE **R10**
COPRIFILO IMPIALLACCIATO **L2**

TELAIO IN MASSELLO **MRC**
COPRIFILO IN MASSELLO **BLC**



TELAIO IN MASSELLO **MR10**
COPRIFILO IN MASSELLO **BLM**

TELAIO IN MASSELLO **MR60**
COPRIFILO IN MASSELLO **LM7**

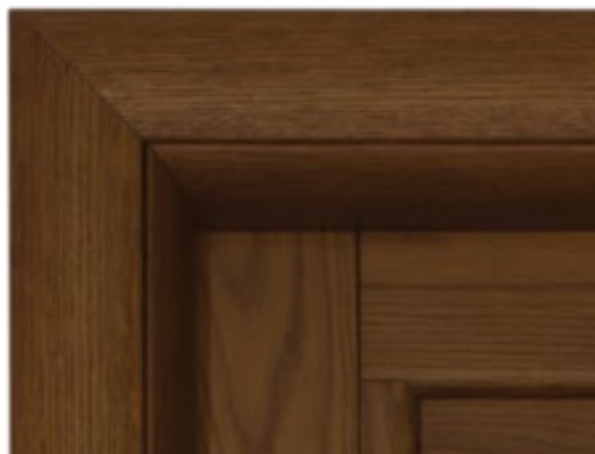

TELAIO IN LISTELLARE **R60**
COPRIFILO IMPIALLACCIATO **L8**

TELAIO IN MASSELLO **MR2**
COPRIFILO IN MASSELLO **FM9**



TELAIO IN LISTELLARE **R2**
COPRIFILO IMPIALLACCIATO **FL10**

TELAIO IN MASSELLO **MK**
COPRIFILO IN MASSELLO **LM9**



TELAIO IN MASSELLO **MK**
COPRIFILO IMPIALLACCIATO **L10**

TELAIO IN LINEA



ESSENZE E FINITURE

PINO



NATURALE



BASE



MEDIO

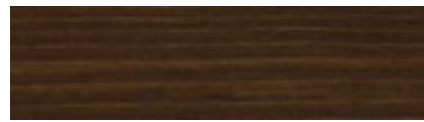

ARTE POVERA

FRASSINO



CHIARO



BASE

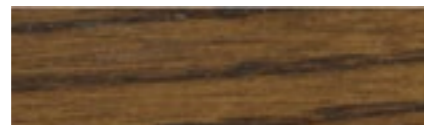

MEDIO

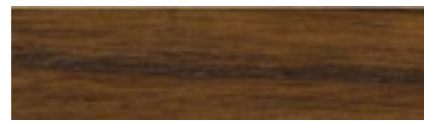

ARTE POVERA

CASTAGNO



MIELE



BASE



MEDIO

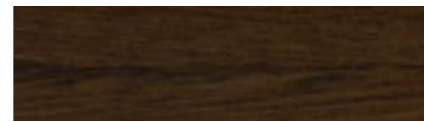

ARTE POVERA

TIGLIO



CHIARO



BASE



MEDIO



CILIEGIO

TOULPIER



CHIARO



BASE

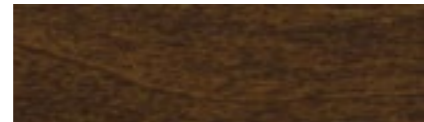

MEDIO

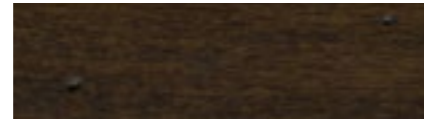

ARTE POVERA

ROVERE



MIELE



BASE



MEDIO



SCURO

N.B.

Le essenze e i colori illustrati in questo catalogo sono da ritenersi puramente indicativi e possono subire modifiche. Eventuali variazioni cromatiche riscontrate sul prodotto sono da imputare al processo produttivo artigianale che attesta il carattere e l'unicità delle Porte Micheloni. L'azienda si riserva il diritto di apportare eventuali modifiche di carattere cromatico e nelle finiture in relazione ad esigenze produttive commerciali.

FINITURE PARTICOLARI

PINO



ARTE POVERA - SPAZZOLATO RUSTICO

TIGLIO



LACCATO BIANCO

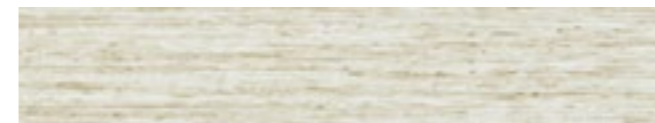

LACCATO ANTICATO

CASTAGNO



NATURALE BIANCO



MEDIO EFFETTO WOOD



ARTE POVERA - SPAZZOLATO RUSTICO

ROVERE

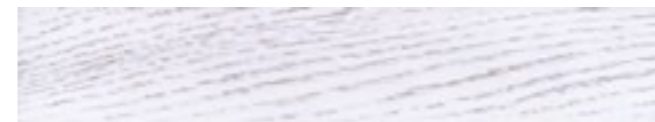

BIANCO INVECCHIATO



NATURALE BIANCO

FRASSINO



LACCATO BIANCO PORO APERTO



LACCATO BIANCO SPAZZOLATO



NATURALE BIANCO



BASE EFFETTO WOOD

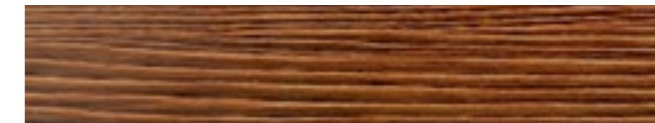

BASE SPAZZOLATO

TOULPIER



LACCATO BIANCO



LACCATO ANTICATO



ARTE POVERA INVECCHIATO



**COLORI RAL
A RICHIESTA**

SCOPRI I VETRI MICHELONI PORTE

Scopri la gamma di vetri che Micheloni Porte ha pensato per ogni gusto e varietà.

- VETRI **SATINATI**
- VETRI **SABBIATI**
- VETRI **INCISI**
- VETRI IN **STAMPA DIGITALE**



BIANCO LATTE

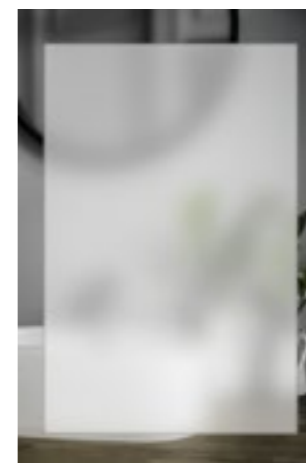

SATINATO
BIANCO



SATINATO
FUMÈ



SATINATO
BRONZO



TRASPARENTE
CLASSICO



TRASPARENTE
FUMÈ



TRASPARENTE
BRONZO



SPECCHIO
CLASSICO



SPECCHIO
FUMÈ



SPECCHIO
BRONZO



VetriSabbati

VETRO STRATIFICATO O TEMPERATO



VETRI SABBBIATI MODERNI

VETRI SABBBIATI CLASSICI



VS-SA-01



VS-02

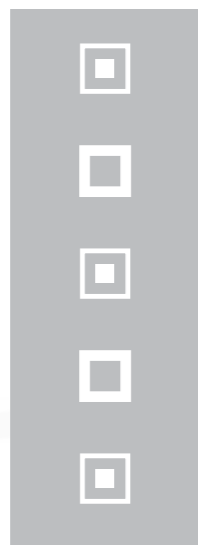

VS-03



VS-04



VS-05



VS-06



VS-13



VS-14



VS-15



VS-16

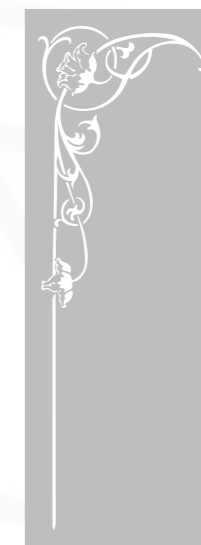

VS-17



VS-18



VS-07



VS-08



VS-09



VS-10



VS-11



VS-12



VS-19

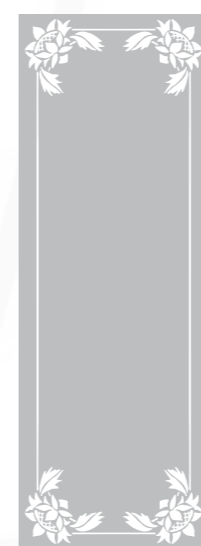

VS-20



VS-21



VS-22



VS-23

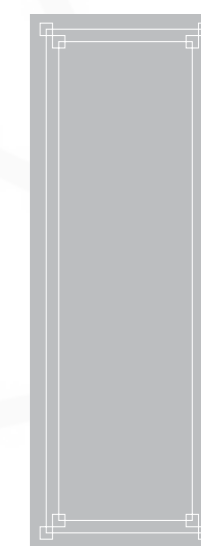

VS-24



Vetri Incisi

VETRO STRATIFICATO O TEMPERATO



VETRI INCISI

CLASSICI



VI-01

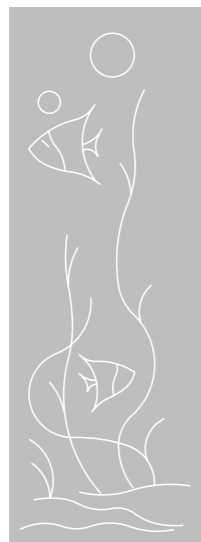

VI-02



VI-03



VI-04



VI-05

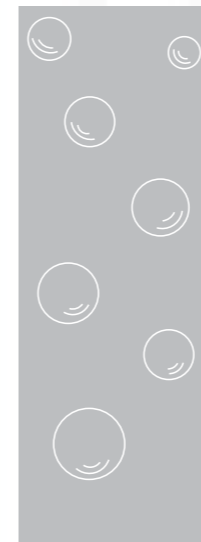

VI-11

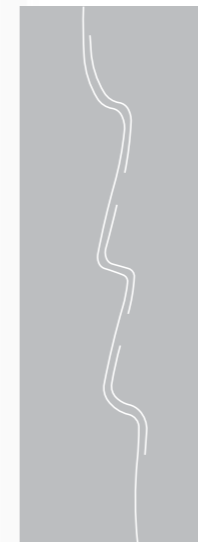

VI-12



VI-13



VI-14



VI-15



VI-06

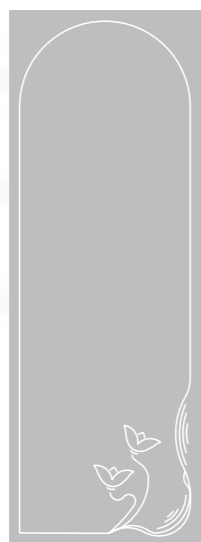

VI-07



VI-08

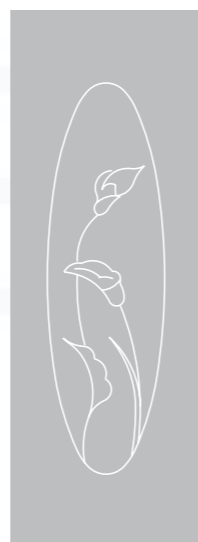

VI-09



VI-10



VI-16



VI-17

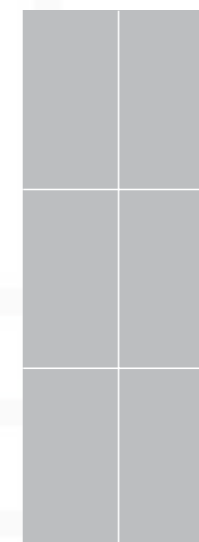

VI-18

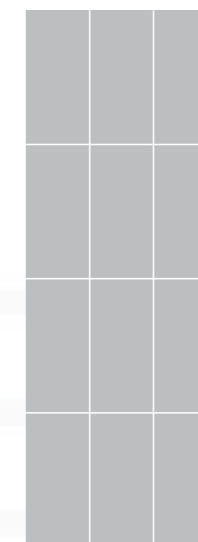

VI-19

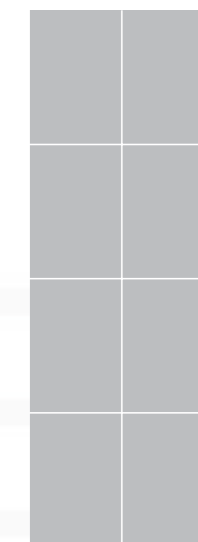

VI-20

VETRI INCISI

MODERNI



VetriStampaDigitale

VETRO STRATIFICATO O TEMPERATO

VETRI STAMPA DIGITALE NEUTRA

VETRI STAMPA DIGITALE COLORE



VP-01

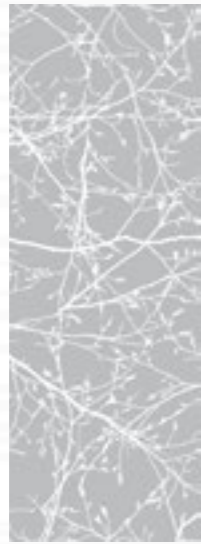

VP-02



VP-03



VP-04



VP-05

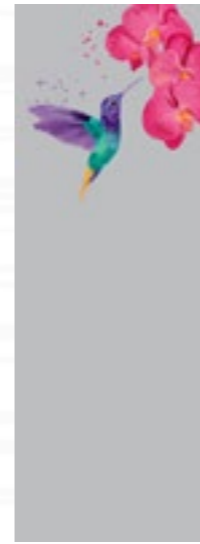

VP-11



VP-12



VP-13



VP-14



VP-15



VP-06



VP-07

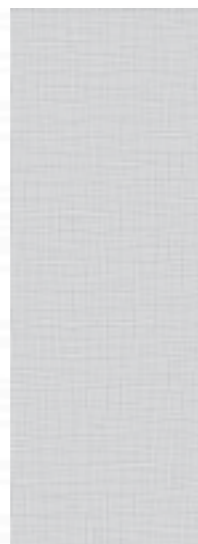

VP-08

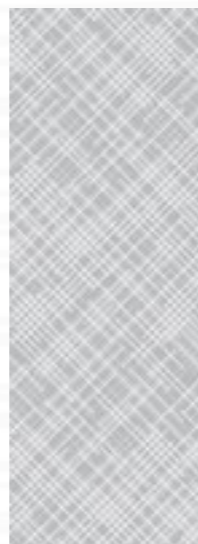

VP-09



VP-10



VP-16



VP-17



VP-18



VP-19



VP-20



MDOOR | WOOD
GLASS
STONE

SCOPRI LE PORTE DEL NUOVO BRAND DEL GRUPPO MICHELONI

MOOR nasce nel 2017 in risposta alle richieste di un mercato sempre in continua evoluzione e alla ricerca costante dei trend più contemporanei. Il brand è composto da porte di carattere e di design, realizzate con nuove tecnologie come la **stampa digitale** su legno e vetro o l'**intarsio in vera pietra**.

Se le linee a catalogo non esprimono al meglio il carattere del cliente, Mdoor prevede anche la personalizzazione della porta in ogni sua parte con l'iniziativa **#CREATIVEMDOOR** che trasforma la porta per creare un prodotto **100% su misura** e personale.

Per avere maggiori informazioni sul brand MDOOR e per scoprire tutte le linee, richiedi il catalogo al tuo agente di zona oppure **visita il sito dedicato www.mdoor.design**



SCOPRI TUTTO IL MONDO MICHELONI,
VISITA IL NOSTRO SITO:
WWW.MICHELONIPORTE.IT